

RECOMMENDED PCB LAYOUT(TOP VIEW)  
(THICKNESS=0.8±0.05mm)  
TOLERANCE = ±0.05

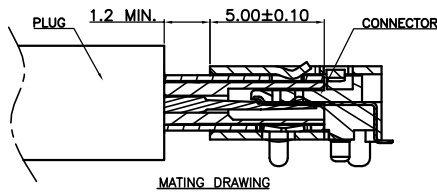
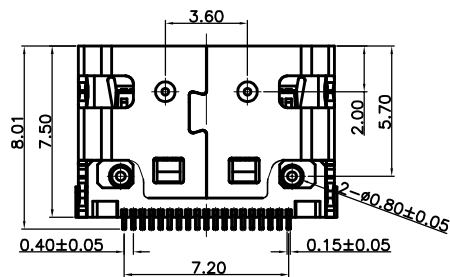
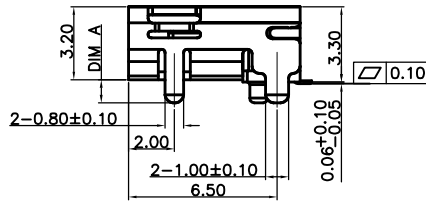
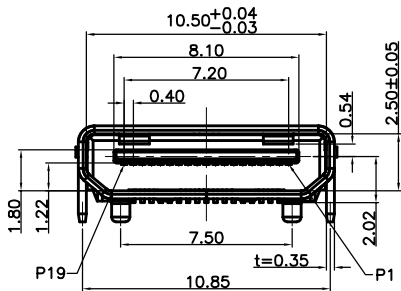

NOTES:

- MATERIAL:
  - HOUSING: LCP, BLACK, UL94V-0
  - SHELL: BRASS
  - TERMINAL: PHOSPHOR BRONZE
  - MYLAR: Pi.
- PLATING:
  - SHELL: GOLD PLATING OVER NICKEL
  - UNDERPLATED/NICKEL PLATING OVER ALL AREA AND TIN PLATING ON SOLDER AREA, NICKEL UNDERPLATING OVER ALL
  - TERMINAL: GOLD PLATING ON CONTACT
- ALL RAW MATERIAL, COMPONENTS, AND PROCESS MUST MEET HAZARD SUSTAIN FREE PER RoHS & REACH STANDARD.

4. P/N:

1166-XXX05-2XX

SHELL MATERIAL & PLATING CODE:  
2: MATERIAL: COPPER ALLOY  
NICKEL PLATING WITHOUT FLANGE  
6: MATERIAL: COPPER ALLOY  
GOLD PLATING WITHOUT FLANGE

LABEL CODE: B  
SHELL LEG LENGTH CODE:  
1: DIM A=1.0  
2: DIM A=1.5  
PACKAGING CODE  
2: Tape Reel

TERMINAL CONTACT  
AREA PLATING CODE:

- A: GOLD FLASH
- B: 3u" GOLD
- C: 15u" GOLD
- △ D: 30u" Au

MYLAR & DATA CODE:

	DATA CODE	W/DATA CODE	W/O DATA CODE
MYLAR			
W/O MYLAR		0	3
W/ MYLAR		2	1

RoHS2+HF

GP TYPE

REV.	DESCRIPTION	ECN NO.	DWN.	CHK.	APVD.	DATE
C	ADD 30u" Plating No.	N1903080	Jiahao			03-25'19
B	ADD GP TYPE	N1607358	Hongrui	Jimmy	Kevin	07-19'16
A	FIRST RELEASED	--	Xuesong	Tonson	Kevin	04-15'13

TOLERANCES UNLESS OTHERWISE SPECIFIED	X. ±0.50
	X.X ±0.30
	X.XX ±0.20
	X.XXX ±0.15
	ANGEL ±3°
MATERIAL	SEE NOTE
FINISH	SEE NOTE

TITLE	HDMI BSF-2 ( HDMI C TYPE FEMALE )		UNIT	mm	
ORIGINAL DATA	04-15'13				
DWN.	Xuesong	SCALE	1:1	SIZE	A3
CHK.	Tonson	REV.			C
APVD.	Kevin	DWG. NO.	C-1166-XXX05-2XX	SHEET	1 OF 2

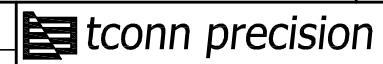

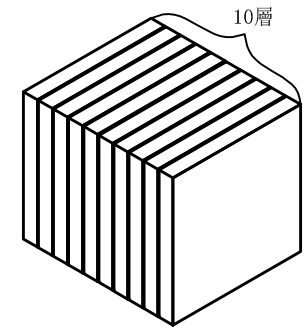
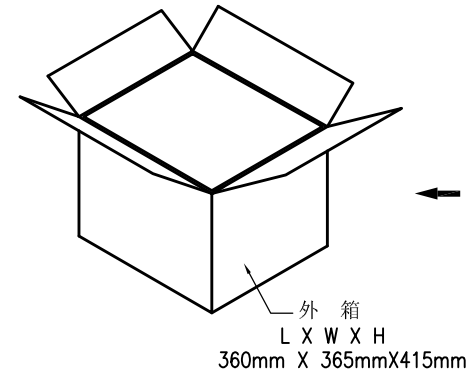
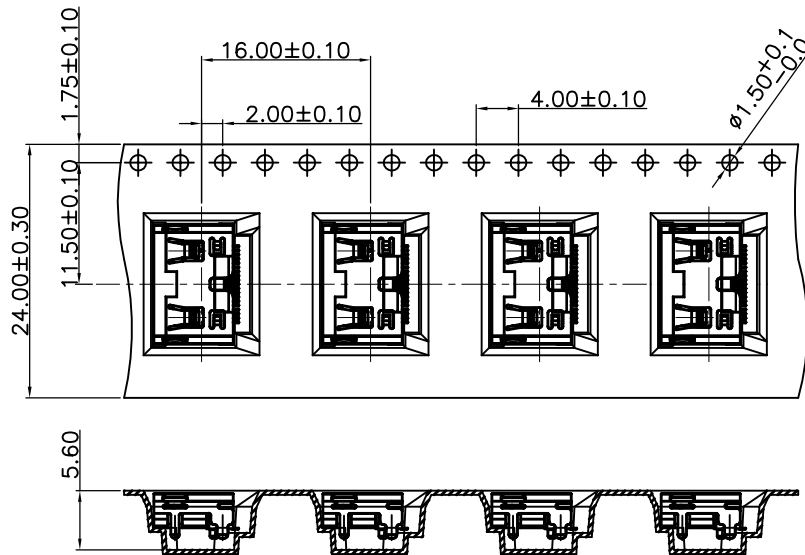
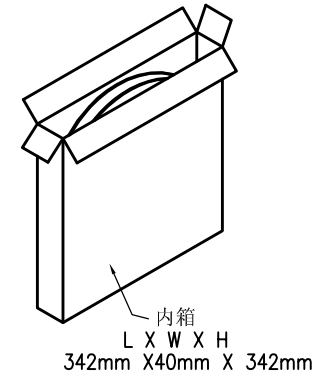
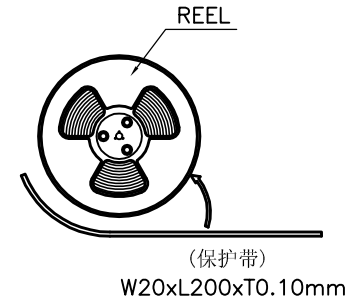
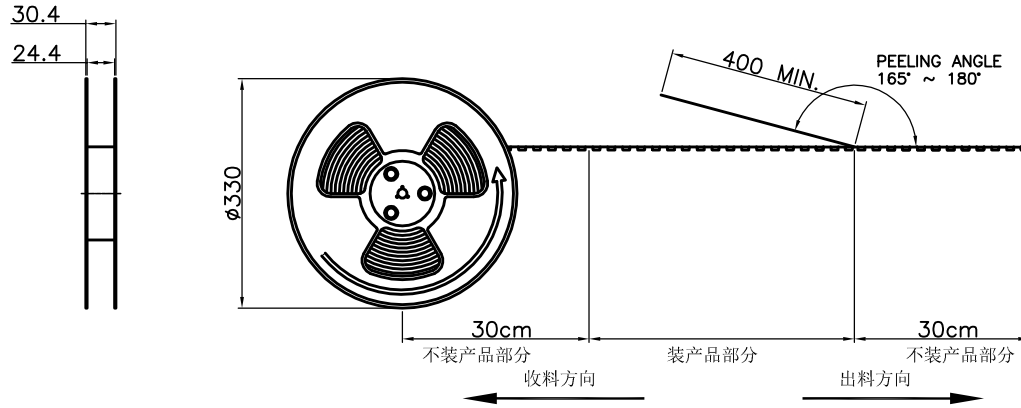

- 注释:
1. 卷带中每位置放置一个产品, 每卷卷带的两端各预留约30cm左右不使用;
  2. 边放产品边用封胶带封口, 1个卷盘放置700个产品;
  3. 然后再卷一圈保护带, 保护带最后重叠约50MM, 用皱纹胶纸将其封住;
  4. 内箱外侧以胶带封口;
  5. 每10个内箱入1个外箱;
  6. 此部分, 禁止使用含有《环境管理物质控制标准》所限制的物质作为材料.

REV.	DESCRIPTION	ECN NO.	DWN.	CHK.	APVD.	DATE
C	ADD 30u" Plating No.	N1903080	Jiahao			03-25'19
B	ADD GP TYPE	N1607358	Hongrui	Jimmy	Kevin	07-19'16
A	FIRST RELEASED	--	Xuesong	Tonson	Kevin	04-15'13

TOLERANCES UNLESS OTHERWISE SPECIFIED		TITLE		UNIT
X.	±0.50	HDMI BSF-2 ( HDMI C TYPE FEMALE )		mm
X.X	±0.30	ORIGINAL DATA		
X.XX	±0.20	04-15'13		
X.XXX	±0.15	DWN. Xuesong		
ANGEL	±3'	CHK. Tonson		
MATERIAL		APVD. Kevin		
SEE NOTE		PART NO. 1166-XXX05-2XX		SCALE 1:1
SEE NOTE		SIZE A3		REV. c
SEE NOTE		DWG. NO. C-1166-XXX05-2XX		SHEET 2 OF 2