

**NOTES:**  
**1.MATERIAL:**  
 1-1 HOUSING:LCP BALCK UL94V-0  
 1-2 TERMINAL:COPPER ALLOY  
 1-3 SHELL:COPPER ALLOY  
**2.PLATING:**  
 2-1 TERMINAL:GOLD FLASH PLATED ON CONTACT AREA, 2.54μm [100μ"] MIN. MATTE-TIN ON SOLDER TAIL, WITH ENTIRE CONTACT UNDERPLATED 1.27μm [50μ"] MIN. NICKEL.  
 2-2 SHELL:PLATING NICKEL  
**3.ELECTRICAL PERFORMANCE:**  
 3-1 CONTACT RESISTANCE:INITIAL CONTACT RESISTANCE EXCLUDING CONDUCTOR RESISTANCE:10 MILLIOHMS MAX.  
 3-2 DIELECTRIC STRENGTH:UNMATED CONNECTORS APPLY 500V AC MATED CONNECTOR APPLY 300V AC  
 3-3 INSULATION RESISTANCE:100 MEGAOHMS MIN.(UNMATED) 10 MEGAOHMS MIN.(MATED)  
**4.INTERNAL THREADS TO WITHSTAND A MINIMUM APPLIED TORQUE OF 2.0 kgf.cm.**  
**5.RECOMMENDED SCREW MOUNTING HARDWARE LESS THAN OR EQUAL TO NOTE 4 SPEC.**

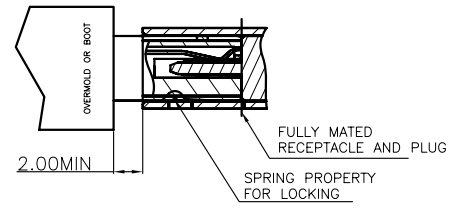
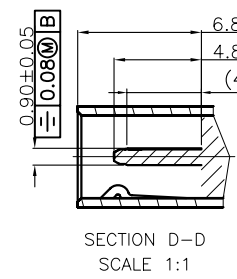
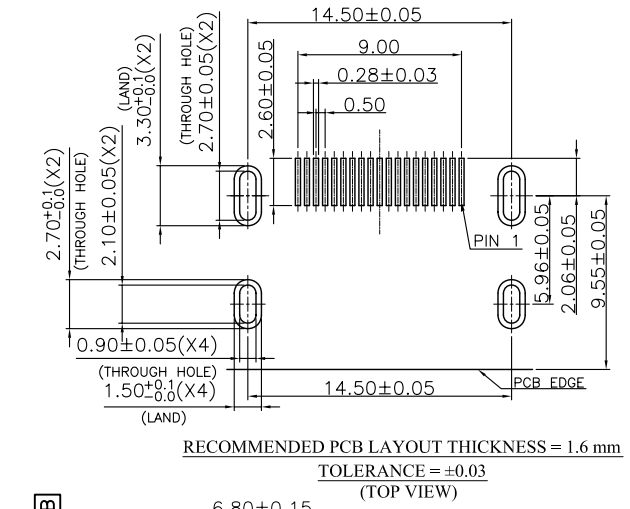
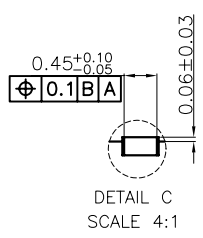
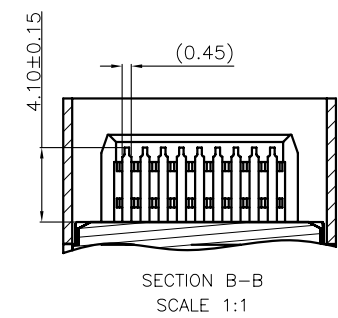
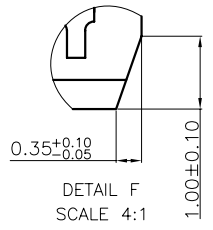
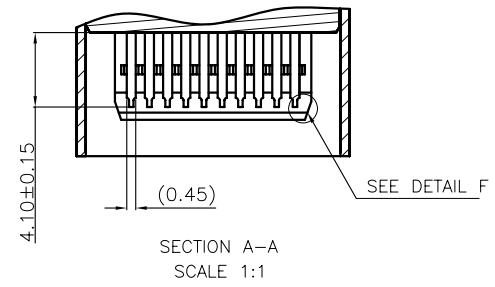
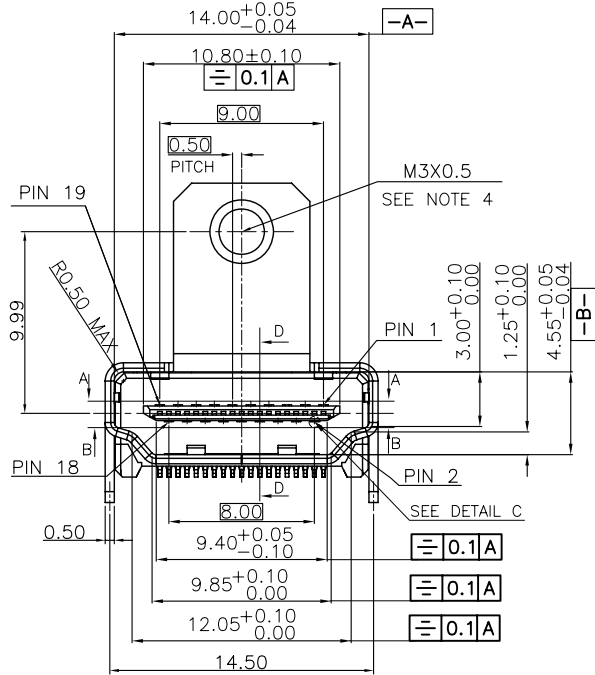

REV.	DESCRIPTION	ECN NO.	DWN.	CHK.	AP'VD.	DATE
G	ADD TRAY DIM.	N1806237	Xianpei			06-21'18
F	MODIFY BOTTOM TRAY MATERIAL	N1608409	Xinye	Jimmy	Kevin	08-15'16
E	MODIFY PACKING	N1605200	Xinye	Jimmy	Kevin	05-05'16
D	MODIFY DIM.	N1511396	ZongShun	Jimmy	Kevin	11-02'15
C	CHANGE PACKING	N1508291	ZongShun	Jimmy	Kevin	08-28'15
B	轉換圖框	--	Jianbo	Jimmy	Kevin	02-19'13

TOLERANCES UNLESS OTHERWISE SPECIFIED  
 X. ±0.50  
 X.X ±0.30  
 X.XX ±0.20  
 X.XXX ±0.15  
 ANGEL ±3°  
 MATERIAL See Note  
 FINISH See Note

TITLE		UNIT
HDMI A TYPE FEMALE 19PIN SMT TYPE (BSA)		mm
ORIGINAL DATA		
02-14'12		
DWN.	Ken	
CHK.	Daniel	
APVD.	Daniel	
PART NO.	SCALE	SIZE
1165-1A072-111	1:1	A3
DWG. NO.	SHEET	REV.
C-1165-1A072-111	1 OF 2	G

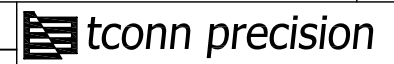

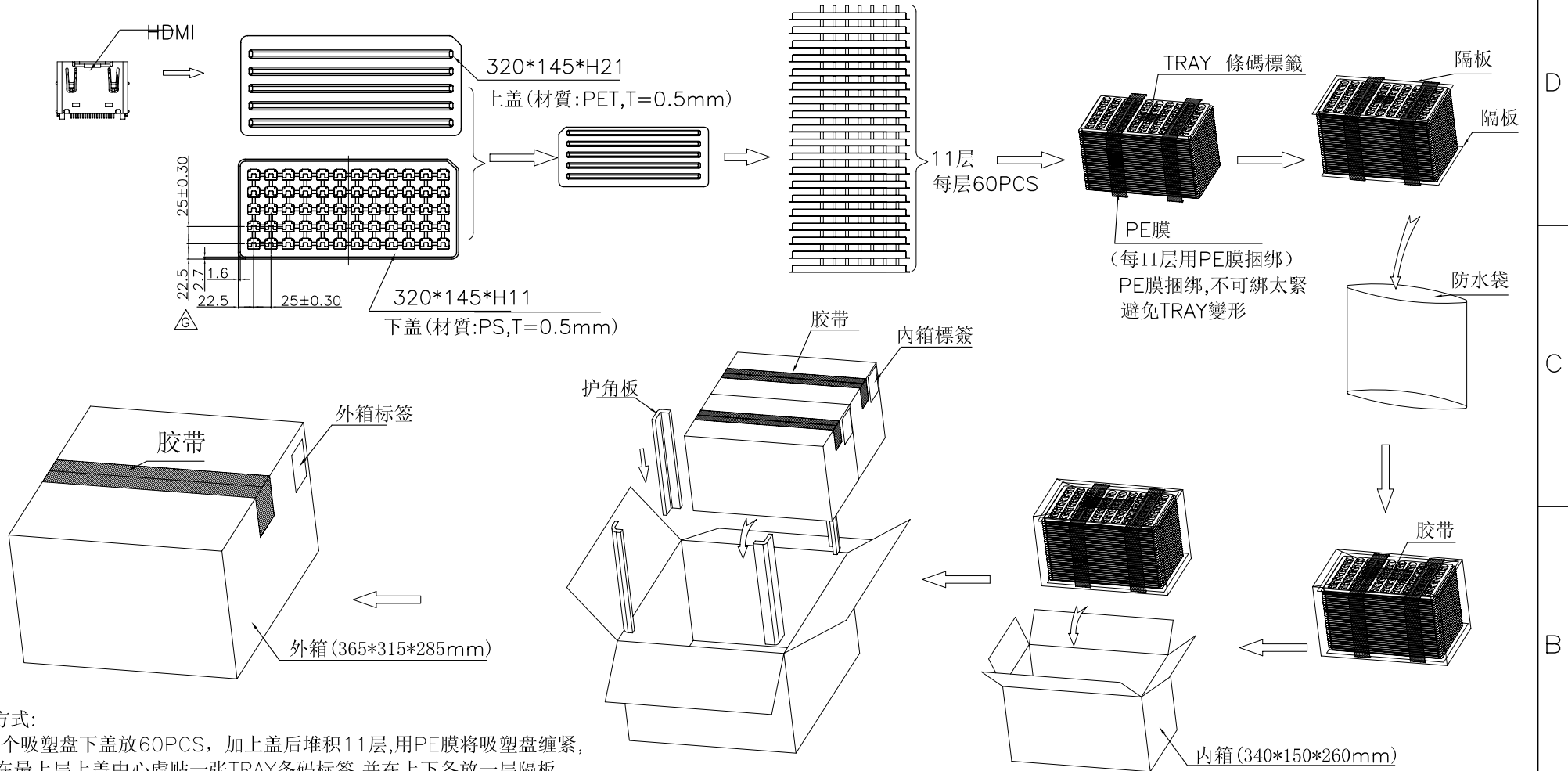

包装方式:

- 1、每个吸塑盘下盖放60PCS, 加上盖后堆积11层,用PE膜将吸塑盘缠紧, 在最上层上盖中心處貼一張TRAY條碼標籤,并在上下各放一层隔板;
- 2、将缠好的吸塑盘及隔板装入防水袋, 然后用膠帶封口, 再装入內箱, 用膠帶將內箱封好, 在图示位置貼好標籤包住然后放入紙箱;
- 3、一个外箱裝2个內箱, 每內箱裝660PCS,每个外箱图示位置貼外箱標籤
- 4、此部品,禁止使用含有《环境管理物质控制标准》所限制的物质作为材料.

60	22	1320PCS	--KG	--KG
PCS/Tray	Tray/BOX	QUANTITY	GROSS	NET
TITLE		HDMI A TYPE FEMALE 19PIN SMT TYPE (BSA)		
ORIGINAL DATA		02-14'12		
DWN.	Ken	PART NO.	SCALE	SIZE
CHK.	Daniel	1165-1A072-111	1:1	A3
APVD.	Daniel	DWG. NO.	C-1165-1A072-111	SHEET
				2 OF 2

G	ADD TRAY DIM.	N1806237	Xianpei			06-21'18	TOLERANCES UNLESS OTHERWISE SPECIFIED
F	MODIFY BOTTOM TRAY MATERIAL	N1608409	Xinye	Jimmy	Kevin	08-15'16	X. ±0.50
E	MODIFY PACKING	N1605200	Xinye	Jimmy	Kevin	05-05'16	X.X ±0.30
D	MODIFY DIM.	N1511396	ZongShun	Jimmy	Kevin	11-02'15	X.XX ±0.20
C	CHANGE PACKING	N1508291	ZongShun	Jimmy	Kevin	08-28'15	X.XXX ±0.15
B	轉換圖框	--	Jianbo	Jimmy	Kevin	02-19'13	ANGEL ±3°
REV.	DESCRIPTION	ECN NO.	DWN.	CHK.	APVD.	DATE	MATERIAL See Note
							FINISH See Note