

- NOTE:
- MATERIAL:
 - HOUSING: LCP E130i UL94V-0,COLOR:BLACK
 - TERMINAL: BRASS C2680 T=0.20mm
 - HDMI SHELL: SUS304 T=0.50mm
 - BAFFLE: SUS304 T=0.20mm
 - SHIELD: SUS304 T=0.20mm
 - PLATING
 - TERMINAL: GOLD(SEE TABLE) PLATED ON CONTACT AREA AND 2.03um [80u"] MIN. MATTE-TIN ON SOLDER TAIL, WITH ENTIRE CONTACT UNDERPLATED 1.27um [50u"] MIN.NICKEL.
 - HDMI SHELL :1.27um [50u"] MIN. NICKEL PLATED.
 - BAFFLE :CLEANING.
 - SHIELD :0.76um [30u"] MIN. NICKEL PLATING.
 - ELECTRICAL CHARACTERISTICS:
 - CONTACT RESISTANCE:30mΩ MAXIMUM
 - CURRENT RATING:0.5A MIN
 - DIELECTRIC WITHSTANDING VOLTAGE:500V AC R.M.S.
 - INSULATION RESISTANCE:UNMATERD 100MΩ MIN.MATED:10MΩ MIN
 - MECHANICAL CHARACTERISTICS:
 - MATING FORCE:4.5kgf MAX
 - UNMATED FORCE:1.0~4.0kgf
 - DURABILITY:10,000 CYCLES
 - OPERATING TEMPERATURE:-20°C~85°C
 - INTERNAL THREADS TO WITHSTAND A MINIMUM APPLIED TORQUE OF 2.0 kgf.cm.
 - RECOMMENDED SCREW MOUNTING HARDWARE LESS THAN OR EQUAL TO NOTE 5 SPEC.

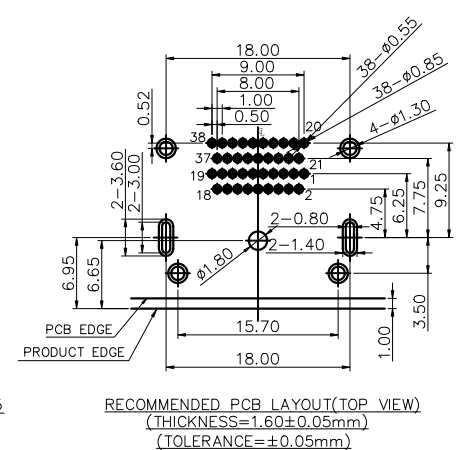

RoHS2+HF	30u"	16-A4350-6A01-0
	15u"	16-A4350-5A01-0
	10u"	16-A4350-3A01-0
	5u"	16-A4350-2A01-0
GP TYPE	G/F	16-A4350-1A01-0
	GOLD THICKNESS	PART NUMBER

						TOLERANCES UNLESS OTHERWISE SPECIFIED		TITLE Double HDMI 2.1 TYPE 38P H=34.40mm CH=3.38mm+CH=23.88mm,REC,STD,DIP TYPE		UNIT mm
						X ±0.50		ORIGINAL DATA		
						X.X ±0.30		09-01'21		
						X.XX ±0.20		DWN. Weihao		PART NO. SEE TABLE SCALE 1:1 SIZE A3 REV. A
						X.XXX ±0.15		CHK. Jimmy		
						ANGEL ±3'		APVD. Kevin		DWG. NO. C-16-A435X SHEET 1 OF 2
						MATERIAL SEE NOTES				
						FINISH SEE NOTES				
REV.	DESCRIPTION	ECN NO.	DWN.	CHK.	APVD.	DATE				
A	FIRST RELEASED	--	Weihao			09-01'21				

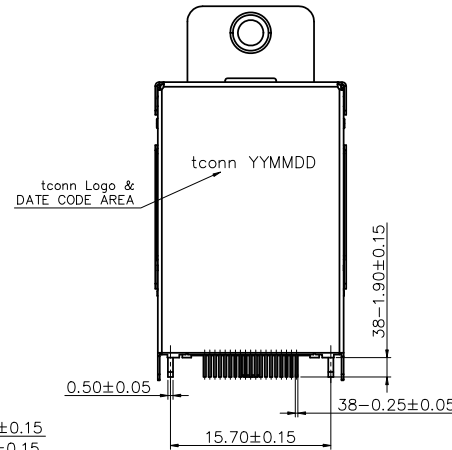
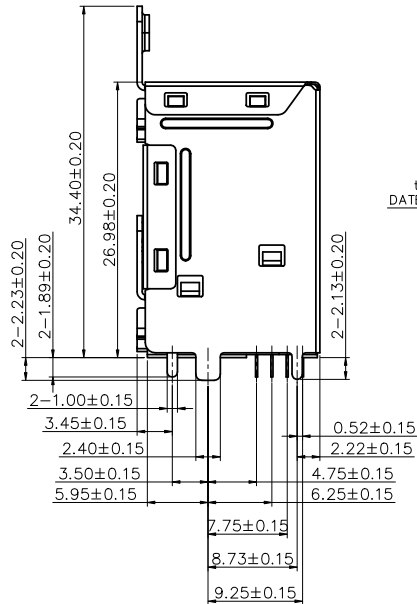
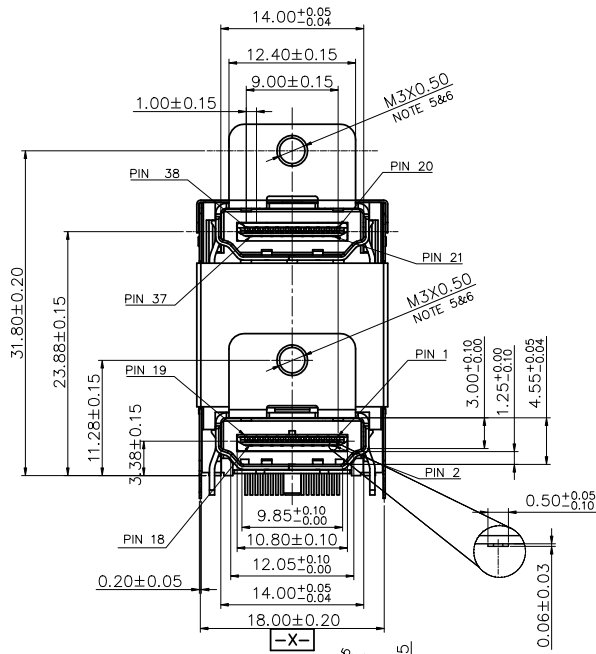
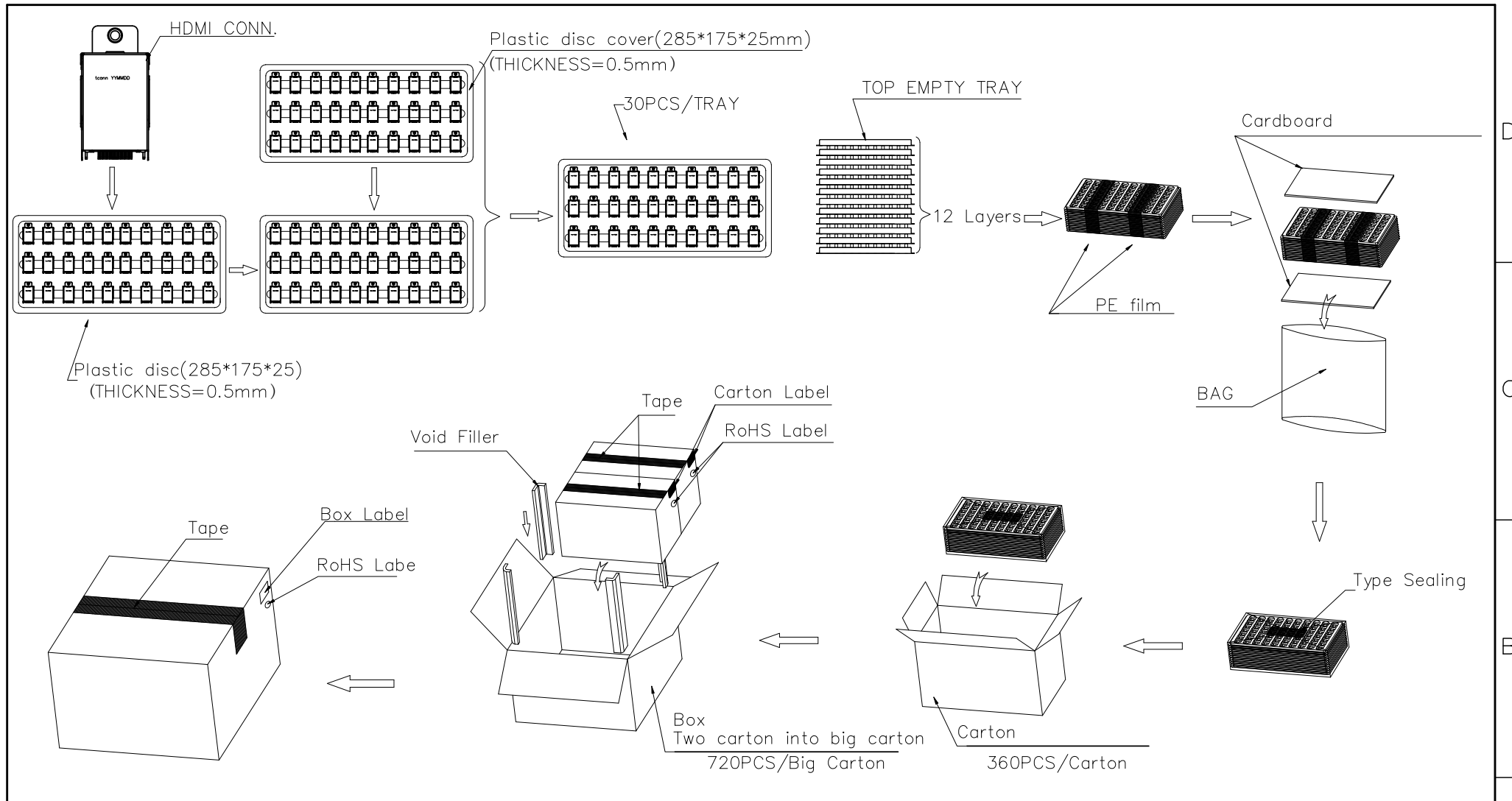

30	24	720 PCS	-- KG	-- KG
PCS/ TAPE	TRAY/ BOX	QUANTITY	GROSS WEIGHT	NET WEIGHT
TITLE Double HDMI 2.1TYPE 38P H=34.40mm CH=3.38mm+CH=23.88mm,REC,STD,DIP TYPE				UNIT mm

REV.	DESCRIPTION	ECN NO.	DWN.	CHK.	APVD.	DATE
A	FIRST RELEASED	--	Weihao			09-01'21

TOLERANCES UNLESS OTHERWISE SPECIFIED
X. ±0.50
X.X ±0.30
X.XX ±0.20
X.XXX ±0.15
ANGEL ±3°
MATERIAL
SEE NOTES
FINISH
SEE NOTES

ORIGINAL DATA 09-01'21	T-CONN PRECISION		
DWN. Weihao	PART NO.	SCALE 1:1	SIZE A3
CHK. Jimmy	SEE TABLE	REV. A	
APVD. Kevin	DWG. NO. C-16-A435X	SHEET 2 of 2	