

NOTE:

- MATERIAL:
  - HOUSING: LCP WITH 30% GF, UL 94V-0, BLACK COLOR.
  - CONTACTS: BRASS T=0.20mm.
  - SHELL: BRASS T=0.50mm.
- FINISH:
  - CONTACTS: (SEE TABLE) GOLD PLATED ON CONTACT AREA, GOLD FLASH MIN ON SOLDER TAIL, WITH ENTIRE CONTACT UNDER PLATED 1.27μm [50μ"] MIN.
  - SHELL: 1.27 μm [50 μ"] MIN. NICKEL PLATED.
- ELECTRICAL PERFORMANCE:
  - 3-1 CONTACT RESISTANCE: INITIAL CONTACT RESISTANCE EXCLUDING CONDUCTOR RESISTANCE: 10 MILLIOHMS MAX.
  - 3-2 DIELECTRIC STRENGTH: UNMATED CONNECTORS APPLY 500V AC MATED CONNECTOR APPLY 300V AC
  - 3-3 INSULATION RESISTANCE: 100 MEGAOHMS MIN.(UNMATED) 10 MEGAOHMS MIN.(MATED)

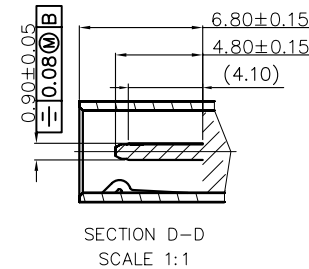
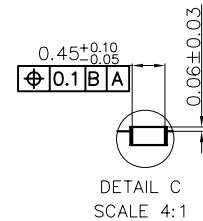
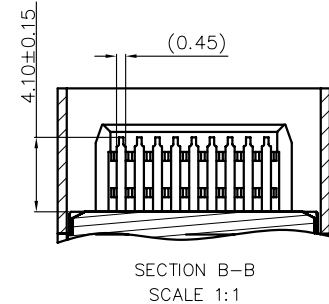
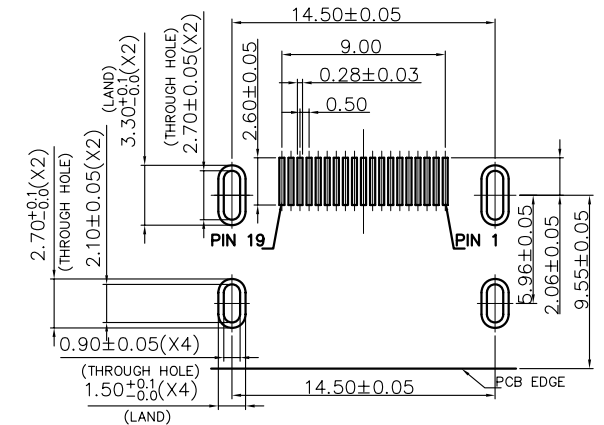
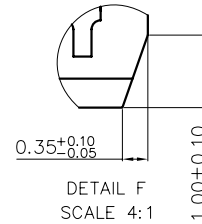
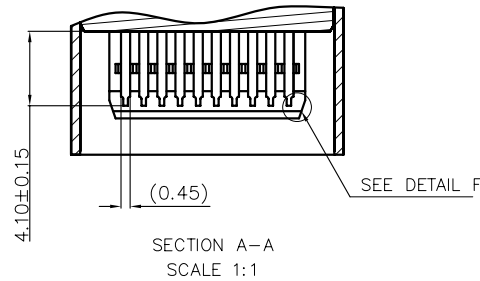
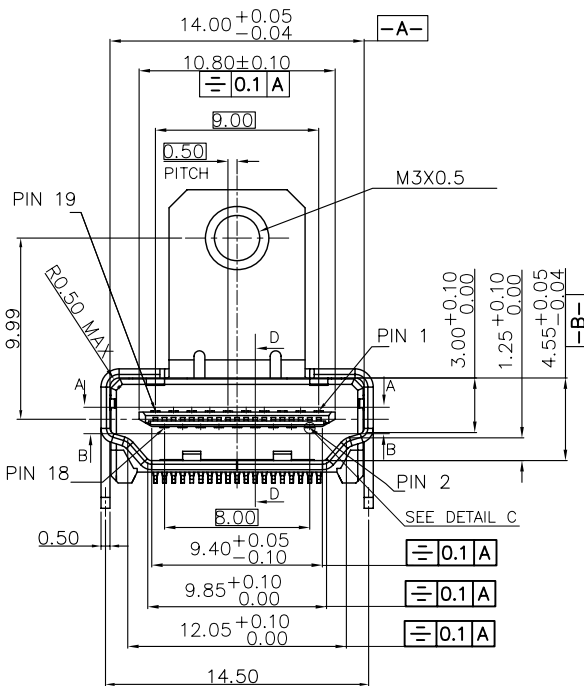

RECOMMENDED PCB LAYOUT THICKNESS = 1.6 mm  
TOLERANCE = ±0.03 (TOP VIEW)

RoHS2+HF	30μ"	16-A3310-6003-0
	15μ"	16-A3310-5003-0
	10μ"	16-A3310-3003-0
	5μ"	16-A3310-2003-0
	GF	16-A3310-1003-0
GP TYPE	PLATING	tconn P/N

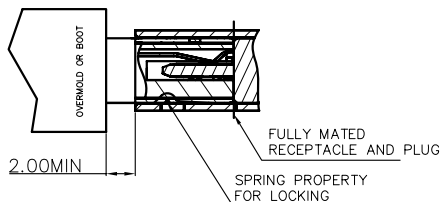

REV.	DESCRIPTION	ECN NO.	DWN.	CHK.	APVD.	DATE
B	CHANGE REEL DIRECTION	N1801018	Xinye			01-08'18
A	FIRST RELEASED	N1709416	Hongrui	Jimmy	Kevin	09-20'17

TOLERANCES UNLESS OTHERWISE SPECIFIED	
X. ±0.50	
X.X ±0.30	
X.XX ±0.20	
X.XXX ±0.15	
ANGEL ±3°	
MATERIAL	SEE Note
FINISH	SEE Note

TITLE	HDMI A TYPE 19P H=16.15 CH=3.50mm, REC,STD,SMT TYPE				UNIT	mm
ORIGINAL DATA	09-20'17					
DWN.	Hongrui					
CHK.	Jimmy				PART NO.	SCALE
APVD.	Kevin				SEE TABLE	1:1
	DWG. NO.				SIZE	REV.
	C-16-A331X				A3	B
	SHEET				1 OF 2	

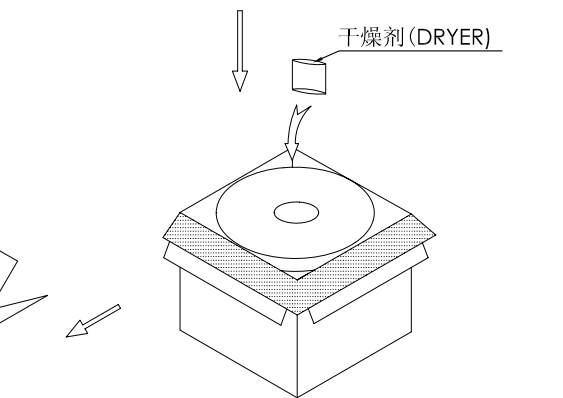
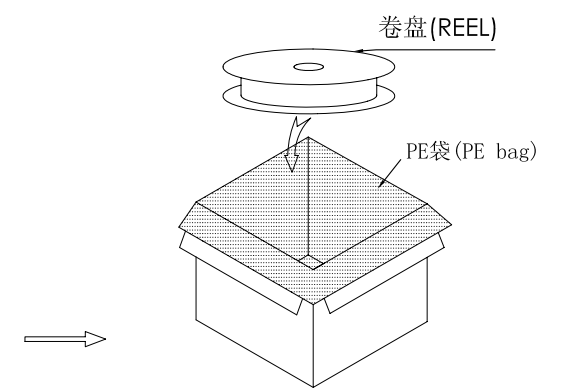
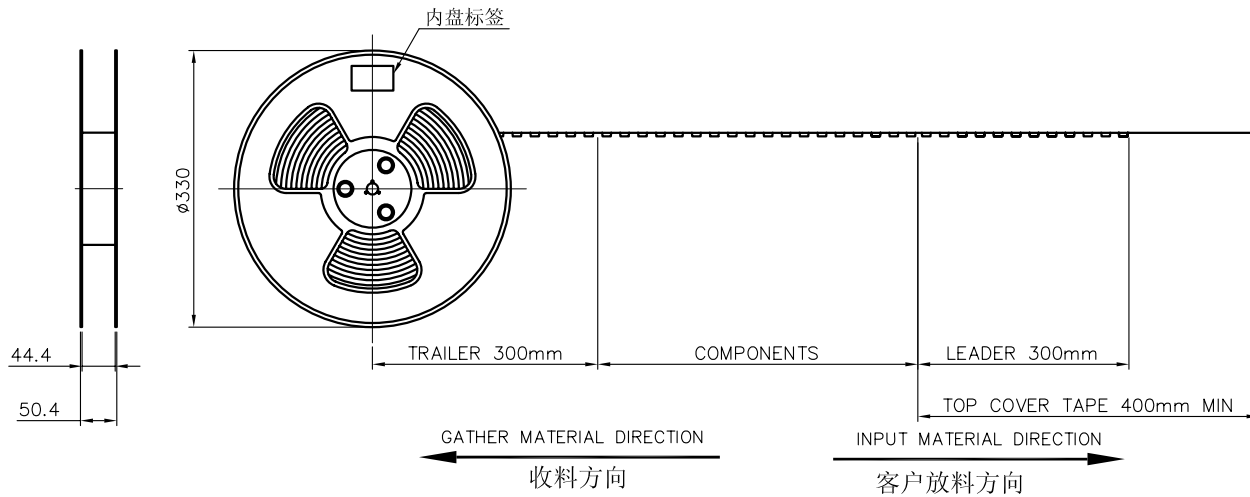

卷盘放置7层，在四个角落各放一袋干燥剂

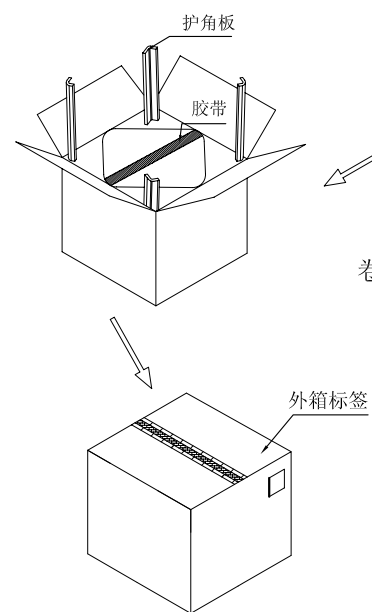
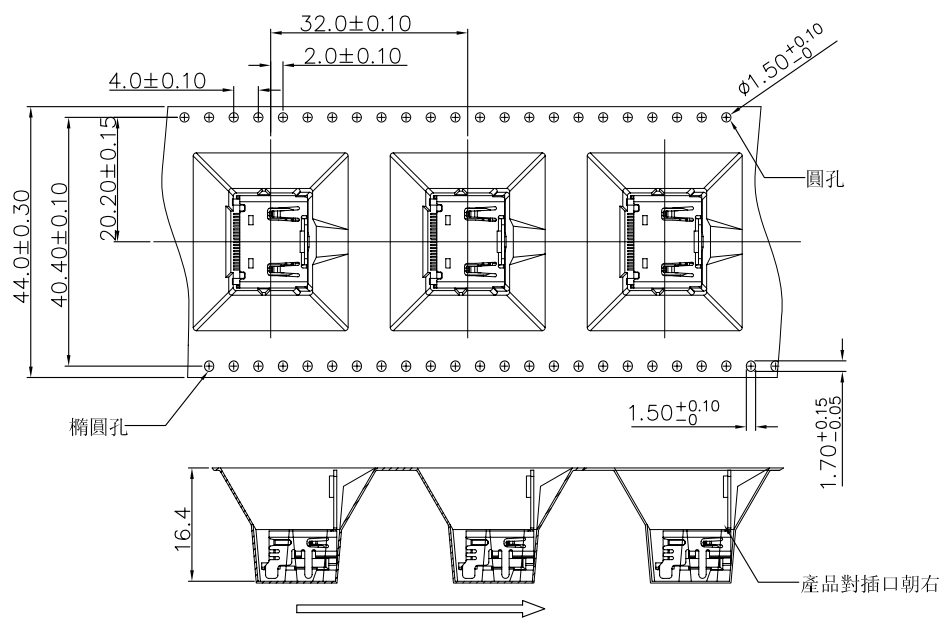

△ 卷带出料方向：产品焊脚朝左，卷带定位圆孔在上，椭圆孔在下。

- NOTE:
- MATERIAL:  
BOX: FIBREBOARD, CORRUGATED, DOUBLE WALL.  
TAPE: POLYSTYRENES, WHITE COLOR.  
REEL: POLYSTYRENES, BLUE COLOR.  
BAG: POLYETHYLENE.
  - PEELING STRENGTH: 0.1 ~ 1.5 N (10 ~ 150 GRAMS)
  - PEELING SPEED: 300 mm/min.
  - EACH BAG SHALL BE INCLUDED DESICCANT.

B	CHANGE REEL DIRECTION	N1801018	Xinye			01-08'18
A	FIRST RELEASED	N1709416	Hongrui	Jimmy	Kevin	09-20'17
REV.	DESCRIPTION	ECN NO.	DWN.	CHK.	APVD.	DATE

TOLERANCES UNLESS OTHERWISE SPECIFIED	
X.	±0.50
X.X	±0.30
X.XX	±0.20
X.XXX	±0.15
ANGEL ±3°	
MATERIAL SEE Note	
FINISH SEE Note	

100	7	700	--KG	--KG
PCS/REEL	REEL/BOX	QUANTITY	GROSS WEIGHT	NET WEIGHT
TITLE HDMI A TYPE 19P H=16.15 CH=3.50mm, REC,STD,SMT TYPE UNIT mm				
ORIGINAL DATA 09-20'17				
tconn precision				
DWN.	Hongrui	PART NO.	SCALE	SIZE REV.
CHK.	Jimmy	SEE TABLE		A3 B
APVD.	Kevin	DWG. NO.	C-16-A331X	SHEET 2 OF 2