

- NOTES:
- MATERIAL:
 - HOUSING:LCP WITH 30% G/F UL 94V-0 COLOR:BLACK.
 - COVER:LCP WITH 30% G/F UL 94V-0 COLOR:BLACK.
 - TERMINAL:COPPER ALLOY C2680 T=0.25mm
 - SHELL:STAINLESS STEEL SUS304 T=0.50mm
 - PLATING:
 - TERMINAL:
 - GOLD (SEE TABLE) PLATED ON CONTACT AREA AND 2.54μm [100μ"] MIN. MATTE-TIN ON SOLDER TAIL, WITH ENTIRE CONTACT UNDERPLATED 1.27μm [50μ"] MIN.NICKEL.
 - SHELL:1.27μm [50μ"] MIN. NICKEL PLATED.
 - ELECTRICAL PERFORMANCE:
 - CONTACT RESISTANCE:INITIAL CONTACT RESISTANCE EXCLUDING CONDUCTOR RESISTANCE:10 MILLIOHMS MAX.
 - DIELECTRIC STRENGTH:UNMATED CONNECTORS APPLY 500V AC MATED CONNECTOR APPLY 300V AC
 - INSULATION RESISTANCE:100 MEGAOHMS MIN.(UNMATED) 10 MEGAOHMS MIN.(MATED)
 - SALT SPAY 48HR PASS.
 - MECHANICAL PERFORMANCE:
 - MATING FORCE:4.5KGF MAX.
 - UNMATING FORCE:1~4KGF.
 - DURABILITY:10000CYCLE.
 - INSERTION FORCE OF CONN INTO PCB 2kgf MAX;
 - WAVE SOLDER:
 - THE CONNECTOR SHALL BE MOUNTED ON THE PCB. THE TEMPERATURE OF THE SOLDER SHALL BE 265+/-5°C AND IMMERSION DURATION:5 SECONDS.

RoHS2+HF	Tray	30u"	16-A1890-6A01-0
		15u"	16-A1890-5A01-0
		10u"	16-A1890-3A01-0
	Carrier tape	5u"	16-A1890-2A01-0
		GF	16-A1890-1A01-0
		30u"	16-A1890-6A03-0
		15u"	16-A1890-5A03-0
		10u"	16-A1890-3A03-0
		5u"	16-A1890-2A03-0
		GF	16-A1890-1A03-0
GP TYPE	PACKING	MIN. GOLD THICKNESS	PART NUMBER

						TOLERANCES UNLESS OTHERWISE SPECIFIED		TITLE		UNIT
						X. ±0.38		HDMI A TYPE 19P H=6.10		mm
						X.X ±0.25		CH=3.33mm,REC,STD,DIP TYPE(BDA-5)		
						X.XX ±0.13		ORIGINAL DATA		
						X.XXX ±0.05		05-26'16		
						ANGEL ±3'		tconn precision		
						MATERIAL		DWN.		
						SEE NOTES		Hongrui		
						FINISH		CHK.		
						SEE NOTES		Jimmy		
						APVD.		Kevin		
A	FRIST RELEASED	N1710456	Hongrui		10-18'17	PART NO.		SCALE	SIZE	REV.
REV.	DESCRIPTION	ECN NO.	DWN.	CHK.	APVD.	DATE	SEE TABLE	1 : 1	A3	A
							DWG. NO.		SHEET	
							C-16-A189X		1 OF 3	

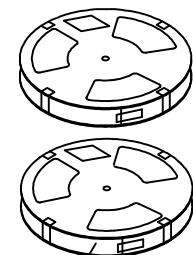
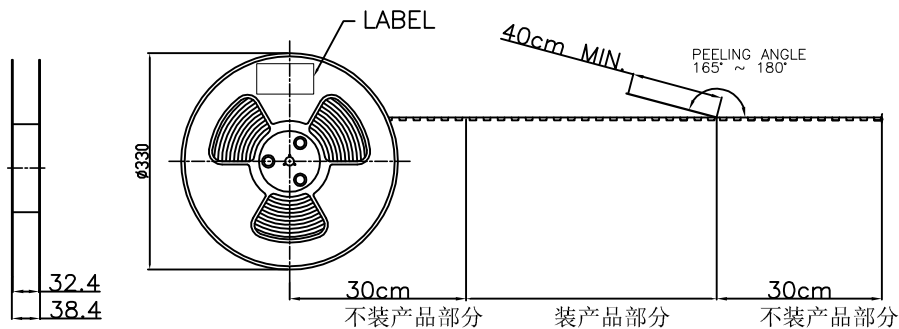

在外箱内套入一个防水袋，然后将装满产品的卷盘放入箱内。每箱装10盘，共计产品3000PCS。

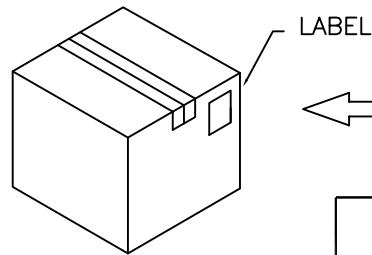
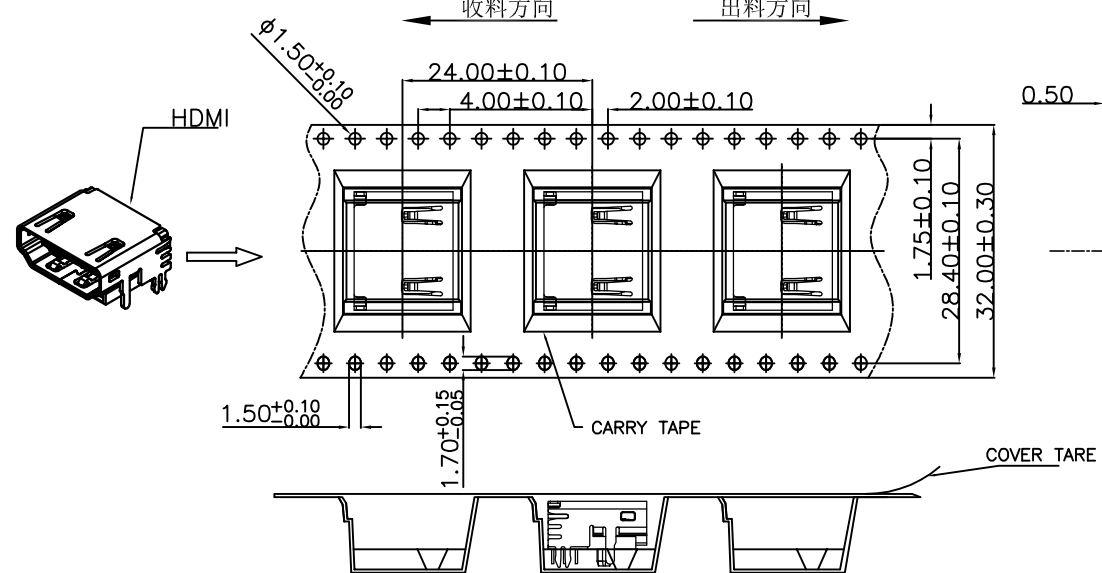
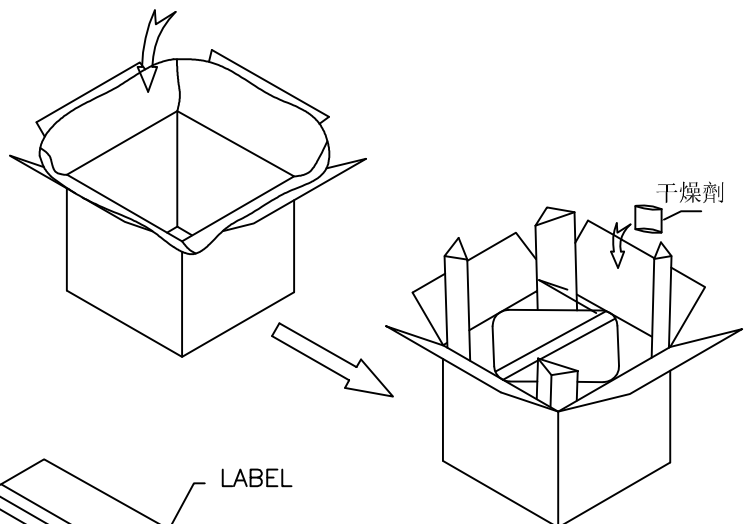

用胶带将防水袋封口，然后在箱的四角各放一个护脚板。

NOTE:
 1. MATERIAL:
 BOX: FIBREBOARD, CORRUGATED, DOUBLE WALL.
 COVER TAPE: POLYSTYRENES, TRANSPARENT COLOR.
 CARRIER TAPE: POLYSTYRENES, TRANSPARENT COLOR.
 REEL: HIPS, , BLUE COLOR.
 BAG: POLYETHYLENE, TRANSPARENT COLOR.
 2. EACH BAG SHALL BE INCLUDED DESICCANT.

PEELING SPEED 250MM~300MM/MINUTE

PULL OUT DIRECTION

COVER TYPE PEELING FORCE:

A	165°~175°
F	0.1N~1.3N

USE FOR P/N		16-A1890-6A03-0		
		16-A1890-5A03-0		
		16-A1890-3A03-0		
		16-A1890-2A03-0		
		16-A1890-1A03-0		
300	10	3000	--KG	--KG
PCS/TAPE	REELS/BOX	QUANTITY	GROSS WEIGHT	NET WEIGHT

REV.	DESCRIPTION	ECN NO.	DWN.	CHK.	APVD.	DATE
A	FIRST RELEASED	N1710456	Hongrui			10-18'17

TOLERANCES UNLESS OTHERWISE SPECIFIED		TITLE		UNIT
X.	±0.38	HDMI A TYPE 19P H=6.10		mm
X.X	±0.25	CH=3.33mm,REC,STD,DIP TYPE(BDA-5)		
X.XX	±0.13	ORIGINAL DATA		
X.XXX	±0.05	05-26'16		
ANGEL	±3°	DWN. Hongrui		
MATERIAL		CHK. Jimmy		
SEE NOTES		APVD. Kevin		
FINISH		PART NO.		SCALE
SEE NOTES		C-16-A189X		1:1
		SIZE		REV.
		A3		A
		SHEET		
		2 OF 3		

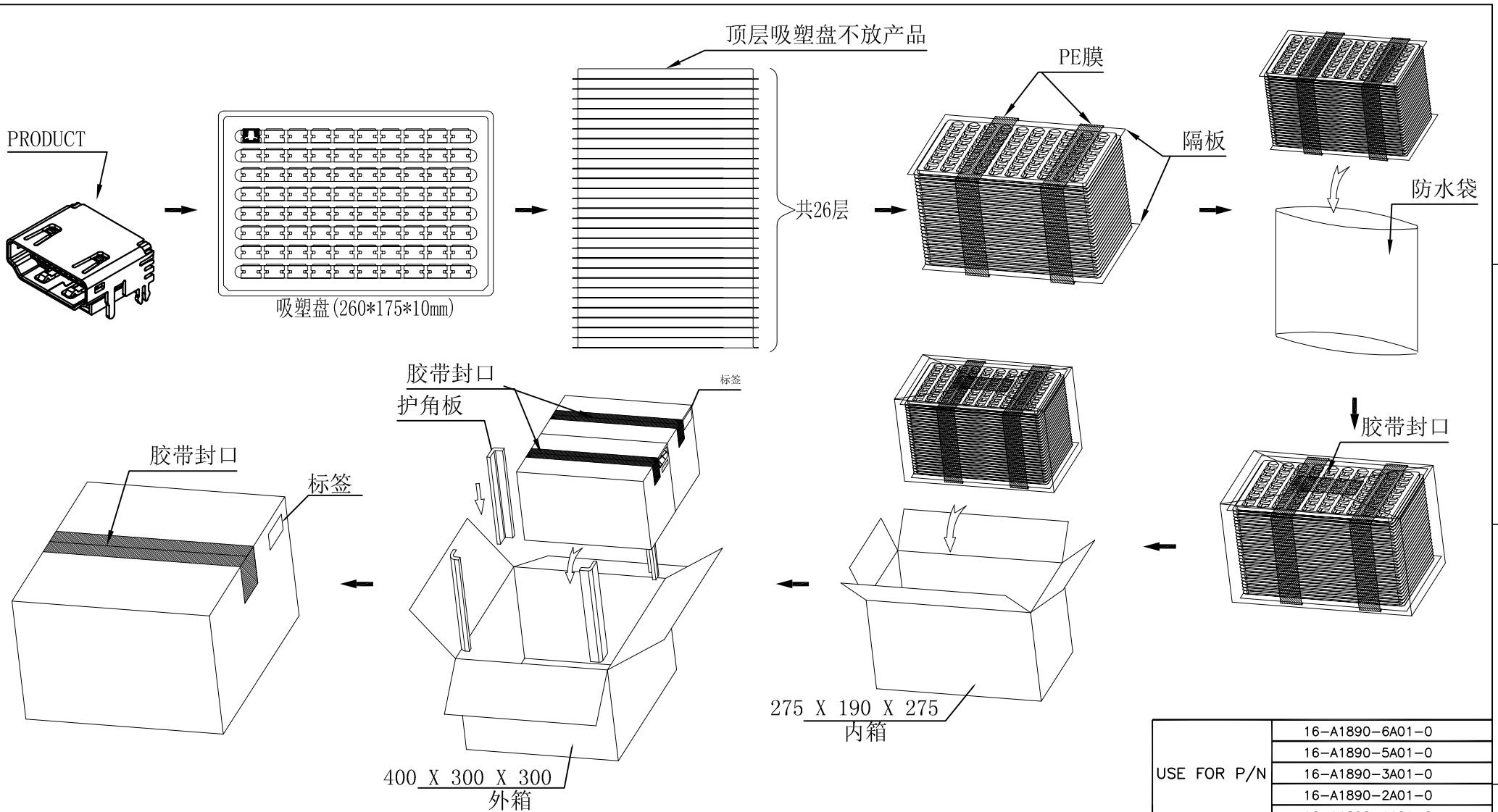

注释:
 1: 每个吸塑盘放80PCS, 每25层加1个空吸塑盘, 并在上下各放一层隔板, 然后用PE膜将隔板及吸塑盘缠紧.
 2: 将缠好的吸塑盘用防水袋包住然后放入内箱.
 3: 每内箱装2000PCS, 2个内箱放入1个外箱, 每个外箱装4000PCS.
 4: 此部品禁止使用含有《环境管理物质控制标准》所限制的物质做为材料.

USE FOR P/N	16-A1890-6A01-0			
	16-A1890-5A01-0			
	16-A1890-3A01-0			
	16-A1890-2A01-0			
	16-A1890-1A01-0			
80	50	4000	--KG	--KG
PCS/TARY	TARY/BOX	QUANTITY	GROSS WEIGHT	NET WEIGHT

						TOLERANCES UNLESS OTHERWISE SPECIFIED		TITLE HDMI A TYPE 19P H=6.10		UNIT	
						X. ±0.38		CH=3.33mm,REC,STD,DIP TYPE(BDA-5)		mm	
						X.X ±0.25		ORIGINAL DATA			
						X.XX ±0.13		05-26'16			
						X.XXX ±0.05		DWN. Hongrui			
						ANGEL ±3'		CHK. Jimmy			
						MATERIAL		APVD. Kevin			
						SEE NOTES		PART NO. SEE TABLE		SCALE 1:1	
						FINISH		DWG. NO. C-16-A189X		SIZE A3	
						SEE NOTES		SHEET 3 OF 3			
A	FRIST RELEASED	N1710456	Hongrui		10-18'17						
REV.	DESCRIPTION	ECN NO.	DWN.	CHK.	APVD.	DATE					