

NOTE :

1. ELECTRICAL CHARACTERISTICS :
  - 1-1. CONTACT RESISTANCE : 40mΩ MAX. FOR 7PIN SIGNAL CONTACTS AND 10mΩ MAX. FOR 4PIN POWER CONTACTS
  - 1-2. DIELECTRIC WITHSTANDING VOLTAGE : 1000VAC FOR 1 MINUTE.
  - 1-3. INSULATION RESISTANCE : 500 VDC/100MΩ MAX.
  - 1-4. CONTACT CURRENT RATING : 15A/2A SHALL BE APPLIED TO POWER/SIGNAL PIN. ΔT < 30°C
2. MECHANICAL CHARACTERISTICS :
  - 2-1. INSERTION FORCE : 5KG(Max.)
  - 2-2. EXTRACTION FORCE : 5KG(min.)
  - 2-3. DURABILITY : 100 CYCLES.
  - 2-4. OPERATING TEMPERATURE : -40°C TO +85°C.
3. HOUSING MATERIAL : GN2450, PA9T ; COLOR : BLACK  
CONTACT MATERIAL : COPPER ALLOY
4. PLATING OPTION :  
CONTACT(SIGNAL) : GOLD PLATING 5u" MIN. ON , 50u" MIN. NICKEL UNDERPLATED OVERALL.  
CONTACT(POWER) : GOLD PLATING 20u" MIN. ON , 50u" MIN. NICKEL UNDERPLATED OVERALL.
5. "⊛" SHOWS INSPECTION ITEMS.
6. PRODUCT FLAME RETARDANT LEVEL: UL94-V0.
7. FOR HAND SOLDERING PROCESS.
8. PACKAGING : TRAY.
9. DATE CODE: tconn YMMDD

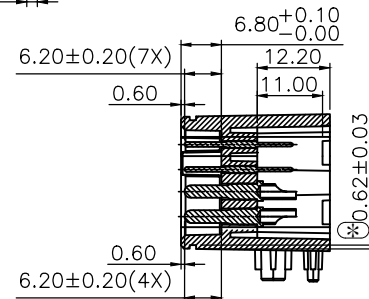
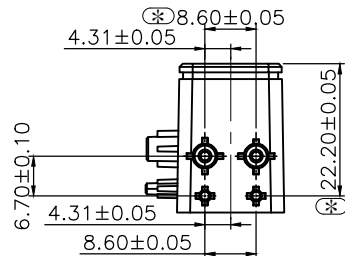
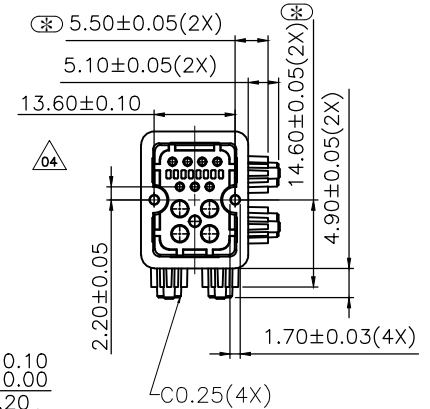
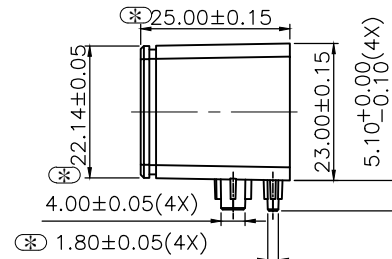
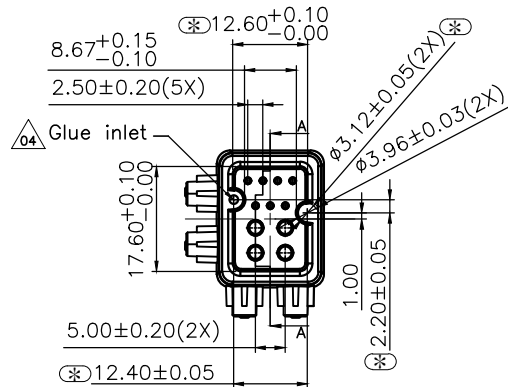
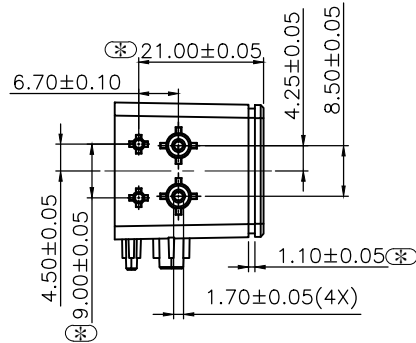

SECTION A-A

							TOLERANCES UNLESS OTHERWISE SPECIFIED	TITLE				UNIT	
							X. ±0.50	SOCKET BATTERY 4+7 PIN MALE				mm	
							X.X ±0.30	ORIGINAL DATA					
							X.XX ±0.20	11-13'19					
							X.XXX ±0.15	DWN.	Kuowei	PART NO.	SCALE	SIZE	REV.
							ANGEL ±3°	CHK.	--	20-01290-C001-0	1 : 1	A3	04
							MATERIAL	APVD.	Victor	DWG. NO.	SHEET		
							SEE TABLE			C-20-0129X	1 OF 2		
							FINISH			1 OF 2			
							SEE TABLE			1 OF 2			
REV.	DESCRIPTION	ECN NO.	DWN.	CHK.	APVD.	DATE							
04	Add Glue inlet & Barrier	N2104126	Hank Lu			04-11'21							
03	PACKING MODIFY	N2006129	Kuowei	--	Victor	06-09'20							
02	DIM. MODIFY	N2006121	Kuowei	--	Victor	06-01'20							
01	NEW DRAWING	--	Kuowei	--	Victor	03-18'20							

NOTE :

- MATERIAL :  
BOX : FIBREBOARD, CORRUGATED, DOUBLE WALL.  
TRAY : EXPANDED POLYETHYLENE FOAM, WHITE COLOR.  
BAG : POLYETHYLENE,
- EACH BAG SHALL BE INCLUDED DESICCANT.
- DIMENSION:  
TRAY : 330\*330\*31  
CARTON : L=345,W=345,H=335
- QUANTITY:  
60 PCS/TRAY  
10 PCS TRAYS/CARTON  
600 PCS PRODUCT/CARTON

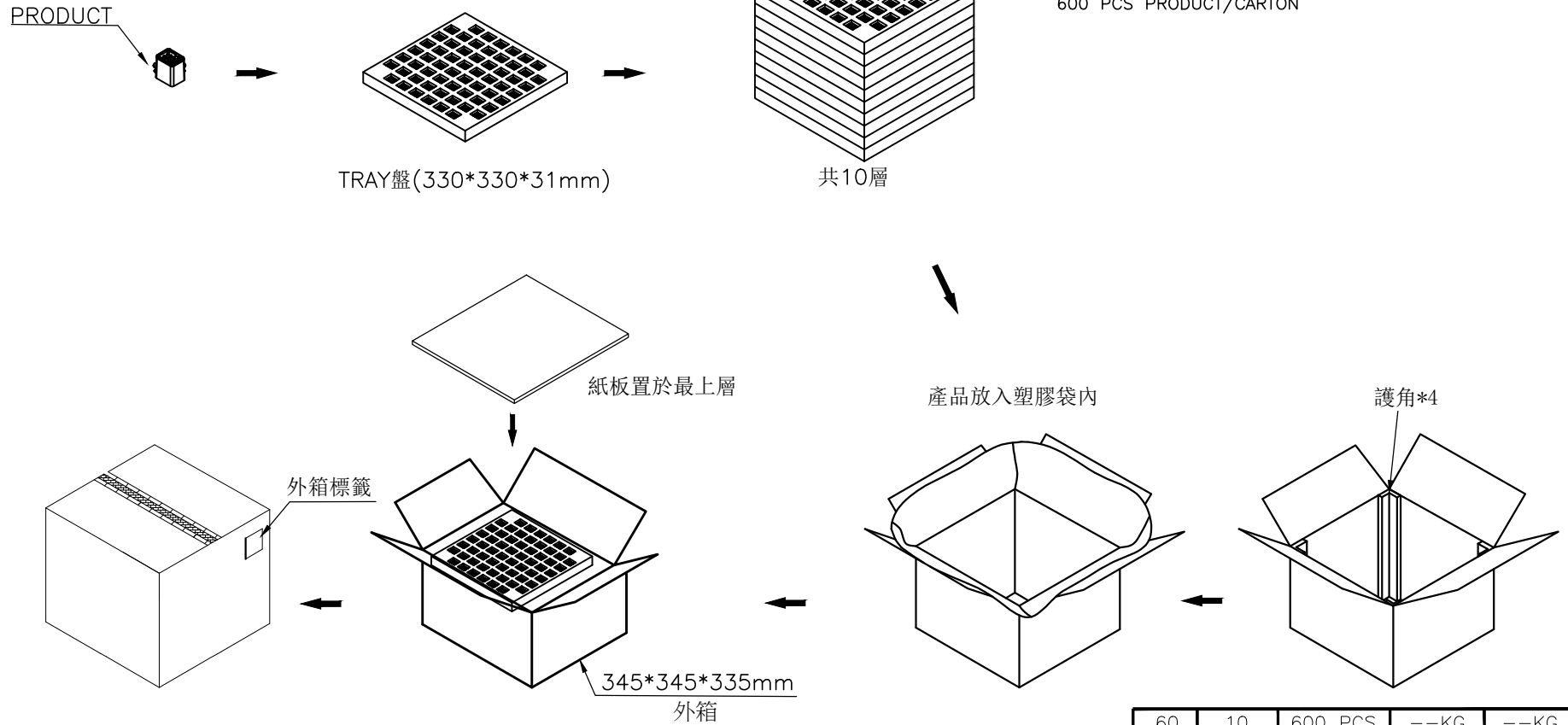

60	10	600 PCS	--KG	--KG
PCS/ TRAY	TYPES/ BOX	QUANTITY	GROSS WEIGHT	NET WEIGHT

REV.	DESCRIPTION	ECN NO.	DWN.	CHK.	APVD.	DATE	TOLERANCES UNLESS OTHERWISE SPECIFIED	TITLE	UNIT
04	Add Glue inlet & Barrier	N2104126	Hank Lu			05-11'21	X. ±0.50 X.X ±0.30 X.XX ±0.20 X.XXX ±0.15 ANGEL ±3'	SOCKET BATTERY 4+7 PIN MALE	mm
03	PACKING MODIFY	N2006129	Kuwei	--	Victor	06-09'20		ORIGINAL DATA 11-13'19	
02	DIM. MODIFY	N2006121	Kuwei	--	Victor	06-01'20	MATERIAL SEE TABLE	DWN. Kuwei	
01	NEW DRAWING	--	Kuwei	--	Victor	03-18'20	FINISH SEE TABLE	CHK. --	
								APVD. Victor	

**T-CONN PRECISION**

PART NO. 20-01290-C001-0	SCALE 1 : 1	SIZE A3	REV. 04
DWG. NO. C-20-0129X	SHEET 2 OF 2		